

# OceanAire

## AirBoss

Air-Cooled Portable  
Air Conditioners



## Polaris

Water-Cooled Portable  
Air Conditioners

**R-410A Models**

# OceanAir

## AirBoss

### Air-Cooled Portable Air Conditioners

### SPECIFICATIONS

MODEL: PAC	1211	1811	2412	3612	3632	3634	6012	6032	6034
Cooling Capacity <sup>1</sup>	12,700	18,010	24,020	36,050	36,050	36,050	60,050	60,050	60,050
Voltage (V/Phase) at 60Hz	115/1		208-230/1	208-230/1	208-230/3	460/3	208-230/1	208-230/3	460/3
Cooling Amps <sup>6</sup>	10.4	14.1	14.9	18.1	17.2	8.7	32.0	20.4	14.8
Cooling Watts <sup>6</sup>	1180	1670	2700	3620	3620	3620	6000	6000	6000
In Rush Current (Amps)	77.5	100.5	90	140	122	122	169	140	140
Plug Type	5-15P	5-20P	6-20P	6-30P	L15-30P	L16-20P	6-50P	L15-30P	L16-20P
EER <sup>3</sup>	10.0	10.0	8.9	10.0	10.0	10.0	10.0	10.0	10.0
Compressor HP	1	1 1/2	2	3	3	3	5	5	5
Compressor RLA	9.5	12.3	10.5	13.6	8.8	5.0	27.6	18.1	9.0
Compressor LRA	50	63	48	83	77	35	158	137	62
Evap CFM <sup>4</sup>	400	600	810	1200	1200	1200	1950	1950	1950
Evap Motor HP	1/8	1/8	1/3	1/3	1/3	1/3	1	1	1
Evap Motor Watts	180	210	330	375	375	375	550	550	550
Condenser CFM	580	930	1010	1390	1390	1390	2200	2200	2200
Condenser Motor HP	1/8	1/8	1/3	1	1	1	1	1	1
Condenser Motor Watts	200	280	350	460	460	460	750	750	750
Condensate	5 Gallon Condensate Tank - STANDARD (Pump Optional)					20 ft (Pump -STANDARD)			
Sound Level <sup>5</sup>	54	60	65	69			78		
R-410A Charge Oz.	18	40	37	66			80		
(A) Height with Casters (in.)	36 1/2	44 1/2		50-1/4			51 1/4		
(B) Width (in.)	20	24		28					
(C) Depth (in.)	25	30		35			39		
(D) Height w/o Casters (in.)	32 1/2	39 1/2		45			45-1/4		
Net Weight (lb.)	180	260	260	365		380	485	485	515
Shipping Weight (lb.)	200	285	285	405		420	525	525	555
Shipping Volume (cu. ft.)	19	28		40			48		

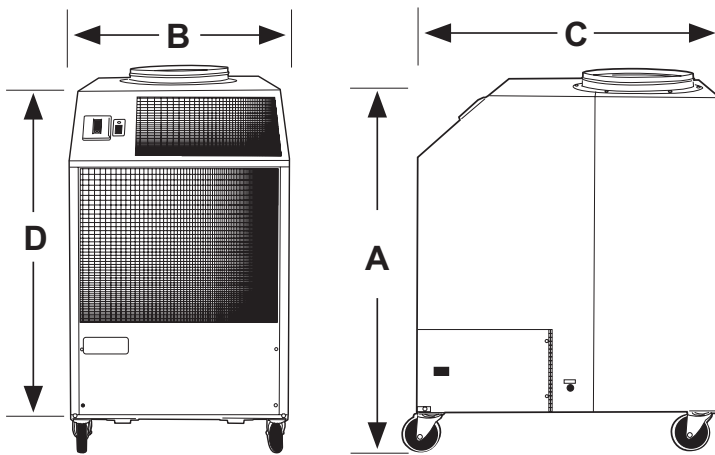

Note: Condenser inlet air plenum adds 13 inches to dimension "C"

#### Specifications subject to change without notice

1. Cooling Capacity is total BTUH at 80°DB/67°WB return air, at high fan speed
2. Time Delay fuses/circuit breakers are recommended
3. EER is determined at high fan speed, with condenser discharge air ducted into another area
4. CFM with free discharge
5. Sound Pressure, dB at 5 feet, commercial operation
6. Amps & Watts at 208 Volts

#### Ambient operating range 65° to 105°

May operate down to 55° if equipped with hot gas bypass (Factory installed)

#### 50 Hz MODELS AVAILABLE - CONSULT FACTORY



# OceanAire

## Polaris

### Water-Cooled Portable Air Conditioners

### SPECIFICATIONS

MODEL: PWC	1211	1811	2412	3612	3632	3634	6012	6032	6034
Nominal Cooling Capacity <sup>1</sup>	12,000	18,000	23,950	36,100	36,100	36,100	60,100	60,100	60,100
Voltage ( Volts/Phase) at 60Hz	115/1		208-230/1		208-230/3	460/3	208-230/1	208-230/3	460/3
Unit Amps <sup>5</sup>	8.1	11.3	9.9	12.0	9.3	4.7	23.7	16.5	6.3
Unit Watts <sup>5</sup>	930	1300	2100	2700	2700	2700	5000	5000	5000
In Rush Current (Amps) <sup>6</sup>	70	90	86.5	99.5	88	88	160	140	140
Plug Type	5-15P	5-15P	6-20P	6-20P	L15-20P	L16-20P	6-30P	L15-30P	L16-20P
EER	12.9	13.8	11.4	13.4	13.4	13.4	12.0	12.0	12.0
Compressor HP	1	1 1/2	2	3	3	3	5	5	5
Compressor RLA	9.5	12.3	10.5	13.6	8.8	5.0	27.6	181	9.0
Compressor LRA	50	63	48	83	77	35	158	137	62
Evap CFM <sup>2</sup>	400	600	810	1200	1200	1200	1950	1950	1950
Evap Motor HP	1/8	1/8	1/3	1/3	1/3	1/3	1	1	1
Evap Motor Watts	180	210	350	375	375	375	550	550	550
Dimension E (in.)	18	21 1/2		29 1/2			32 3/4		
Dimension F (in.)	5 1/2	6		6			6		
Dimension G (in.)	3 1/2	4 1/2		4 1/2			4 1/2		
Cond Water Flow (GPM) at 60°F inlet	0.75	1.1	1.55	2.2	2.2	2.2	5.5	5.5	5.5
at 85°F inlet	3	4.5	6	9	9	9	15	15	15
Cond Coil Pressure Drop-PSI	0.4	0.4	0.2	0.4	0.4	0.4	0.4	0.4	0.4
Water Valve Pressure Drop PSI	2.0								
Water Valve Connection <sup>4</sup>	3/8 MF			5/8 MF					
Drain (Return) Connection	3/8 MF			5/8 MF					
Condensate Pump (ALL UNITS)	20 Ft Lift - 3/8 MF Connection On Unit - DRAIN								
Sound Level <sup>3</sup>	52	57	60	62	62	62	69	69	69
R-410A Charge Oz.	14	18	16	24	24	24	52	52	52
(A) Height with Casters (in.)	31 1/2	37 1/2		50-1/4			52-1/2		
(D) Height Without Casters (in.)	28 1/2	34 1/2		45			46-1/2		
(B) Width (in.)	20 1/8	24 1/4		28 1/4					
(C) Depth (in.)	13 1/8	13		18			39		
Net Weight (lb.)	110	150	160	240		270	460		520
Shipping Weight (lb.)	130	170	180	270		300	500		560
Shipping Volume (cu.ft.)	9	12		23			46		

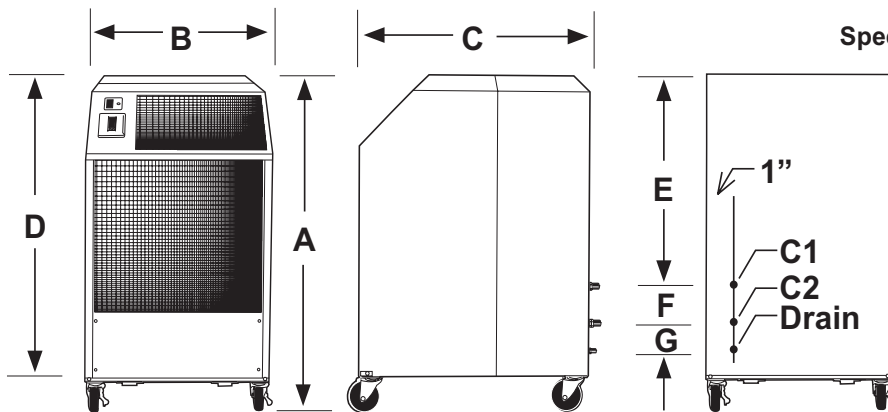

#### Specifications subject to change without notice

1. Nominal capacity is total BTUH at 80°DB/67°WB return air, high fan speed, with 85°EWT to 95°LWT (3 GPM per Ton)
2. CFM with free discharge
3. Sound Pressure, dB at 5 feet, commercial operation
4. 3/8" water valve on models 12, 18, 24 (with 3/8" flare fitting), 3/4" water valve on models 36, 60 (with 5/8" flare fitting)
5. Amps and Watts at 208 Volts
6. Time delay fuses/circuit breakers are recommended

#### Ambient operating range 65° to 105°

May operate to 55° if equipped with optional hot gas bypass (factory installed)

**50 Hz MODELS AVAILABLE - CONSULT FACTORY**

#### WATER CONNECTIONS

For Model 12, C1 = WATER OUT, C2 = WATER IN

For Models 18, 24, 36 & 60, C1 = WATER IN, C2 = WATER OUT



### PAC ACCESSORIES

NOZZLE KIT		MODELS
2NK-1	(2 x 4-INCH)	PAC12
2NK-2	(2 x 6-INCH)	PAC18, 24
2NK-3	(2 X 8-INCH)	PAC36, 60

EVAPORATOR RETURN AIR PLENUM		MODELS
DEP-10	(10-INCH)	PAC12
2DEP-12	(12-INCH)	PAC18, 24
DEP-16	(16-INCH)	PAC36, 60

DISCHARGE DUCT ADAPTER		MODELS
2DDA-6	(6-INCH)	PAC12
2DDA-10	(10-INCH)	PAC18, 24
2DDA-16	(16-INCH)	PAC36, 60

CONDENSER RETURN AIR PLENUM		MODELS
2DCP-1	(12-INCH)	PAC12
2DCP-2	(12-INCH)	PAC18, 24
2DCP-4	(2 X 12-INCH)	PAC36, 60

CEILING PANEL KIT (CONDENSER DISCHARGE)		MODELS
CK-12	(12-INCH)	PAC12, 18, 24
CK-16	(16-INCH)	PAC36, 60
CK-12PL	CK-12 WITHOUT DUCT FLANGE	
CKP-12	2 X 2 CEILING PANEL WITH 12-INCH FLANGE	
CKP-16	2 X 2 CEILING PANEL WITH 16-INCH FLANGE	

DUCT FLANGE		MODELS
DF-12	12-INCH DUCT FLANGE	
DF-16	16-INCH DUCT FLANGE	

CONDENSATE PUMP KITS (NOT FOR SIZE 60)		MODELS
PC-1P	115V MODELS	
PC-2P	230V MODELS	

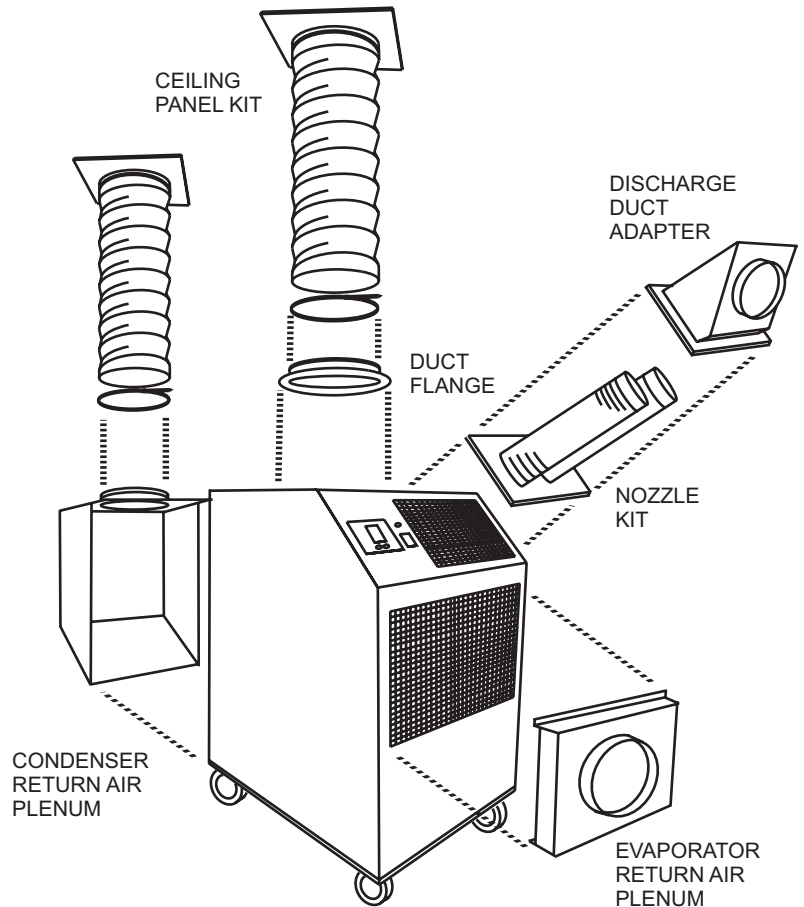

### PWC ACCESSORIES

NOZZLE KIT		MODELS
NK-1	(2 x 4-INCH)	PWC12
NK-2	(2 x 6-INCH)	PWC18, 24
2NK-3	(2 X 8-INCH)	PWC36
NK-3	(2 X 8-INCH)	PWC60

EVAPORATOR RETURN AIR PLENUM		MODELS
DEP-10	(10-INCH)	PWC12
DEP-12	(12-INCH)	PWC18, 24
DEP-16	(16-INCH)	PWC36, 60

DISCHARGE DUCT ADAPTER		MODELS
DDA-6	(6-INCH)	PWC12
DDA-10	(10-INCH)	PWC18, 24
2DDA-16	(16-INCH)	PWC36
DDA-16	(16-INCH)	PWC60

HOSE KIT		MODELS
HK-1	(10 FT)	PWC12, 18, 24
HK-2	(20 FT)	PWC12, 18, 24
HK-5	(40 FT)	PWC12, 18, 24

HK-3	(10 FT)	PWC36, 60
HK-4	(20 FT)	PWC36, 60
HK-6	(40 FT)	PWC36, 60

