

Data Center Racks

# Vantage S2 Enclosure System

Switch  N to Eaton.

**EATON**

*Powering Business Worldwide*

Celebrating  
**100** YEARS  
Ideals that Endure

# The Lean Data Center



Data center managers are constantly moving, adding and changing IT equipment and electrical circuits—all while trying to reduce or maintain costs. This rate of change, combined with the pressure to control costs and the influence of virtual environments, forces data center managers to do more with less.

So how do you achieve a lean operation? Simply put, choose a business partner that can truly consolidate your enclosure, airflow and power management, security and service needs under one umbrella. Work with Eaton, a data center infrastructure partner you can trust.

## The benefits are three-fold:

- Vendor consolidation reduces procurement costs
- Complete, pre-configured solutions increase speed of deployment
- Working direct with the manufacturer increases quality control

Our single-order flow, just-in-time manufacturing process and focused efforts result in an unprecedented low defect and corrective action rate.

At Eaton, we've served a very loyal customer base for a 100 years and the benefits we reap, we pass on to our clients.

# Store, Cool, Power, Manage & Secure

## 1. Store

- Enclosure platform is cost effective and versatile to keep pace with the rapidly evolving server market
- Exact 24" (610mm) enclosure width is designed to complement the North American standard 24" x 24" (610mm x 610mm) tile—preventing end-of-row creep
- Guaranteed compatibility with TIA/EIA-310-D\* standard size equipment
- Fully welded frame rated for 2,000 pound (909kg) static and dynamic load capacity handles even the heaviest server equipment
- Customizable to address individual customer needs
- Rolls through a 7' (2,130mm) doorway to ease deployment
- Offers top access for adjustment of leveling feet, increasing speed of deployment

## 2. Cool

- Provides superior airflow with its fully perforated front and rear door system
- Exceeds most server manufacturers' requirements for open perforation airflow with 940 sq. in. (60,650mm<sup>2</sup>) of open perforation
- Eaton's patented Heat Containment System (HCS) cools up to 25 kW or more per enclosure, without the expense of adding supplemental CRAC units to your data center
- HCS separates hot exhaust air and cold supply air; dramatically increasing the reliability of the data center
- Extends existing cooling capacity throughout the data center; freeing up stranded assets and lowering operational costs

## 3. Power

- Basic, monitored and switched power distribution solutions to fill individual outlet monitoring and management requirement at the enclosure level
- Wide variety of custom and standard options for all power densities and 400V solutions
- Uninterruptible Power Supply (UPS) solutions address the growing need for power availability
- Broad range of UPS solutions guard against power failure, power sag, power surge and a number of other potential downtime events
- Both tower and rackmount style available

## 4. Manage

- Easily accommodates up to 800 CAT5e/6 cables without bends or breaks
- Broad offering of cable management accessories for proper cable distribution and management
- Overhead cable management system offers flexibility and ease of deployment
- Comprehensive environmental monitoring devices provide advanced detection of emerging problems
- Devices provide predictive failure analysis—allowing you to act, rather than react

## 5. Secure

- Our 125 different lock core options provide customized access to individual areas or applications in the data center
- An array of electronic locks are offered for remotely managed access
- A wide variety of security devices minimize damage and unauthorized access
- Security devices provide protection rather than detection



\*TIA (Telecommunications Industry Association) – EIA (Electronic Industries Alliance)

# Frequent technology refreshes — one enclosure platform

The data center has undergone major changes over the past decade. Data centers built 10–15 years ago have infrastructure that is far outdated in terms of the technology it must support. The rapid rate of technological innovation combined with the immense amounts of data being created and the growing need for instantaneous access to that data have created a highly evolving IT environment.

The Vantage S2 enclosure platform has been designed with change in mind, which is why so many Fortune 500 companies have standardized on it.

Eaton's forward-thinking design engineers continue to develop scalable enclosure solutions to help customers store their latest technology without having to change enclosure platforms, allowing them to maximize their original investment. Eaton is so confident that the Vantage S2 enclosure will suit your needs that we offer a "Compatibility Guaranteed" policy. It guarantees that we can offer a solution to store your server and network equipment in the Vantage S2 or we will give you a full refund.\*



## Vantage S2 Size Specifications

Depths (over doors)	12U	25U	42U	45U
39" (991mm)	X	X	X	X
42" (1069mm)		X	X	X
48" (1219mm)			X	X

Widths (w/o sides)	12U	25U	42U	45U
24" (610mm)	X	X	X	X
30" (762mm)			X	X

## COMPATIBILITY GUARANTEED

\* We guarantee that all 19" TIA/EIA-310-D compliant equipment will physically fit into the Vantage S2 enclosure. This guarantee includes all equipment that complies with the TIA/EIA-310-D standard with the mounting hardware provided by the original equipment manufacturer (OEM). OEM server rails may be required. Eaton will not be responsible for equipment that physically fits into the enclosure, but does not comply with TIA/EIA-310-D.



**24" (610mm) wide enclosure**  
Standard server enclosure optimizes the footprint in the data center with its exact 24" (610mm) width that eliminates end-of-row creep.



**30" (762mm) wide enclosure**  
The wider Vantage S2 comfortably accommodates network equipment as well as hybrid environments where large amounts of cables are required.



**39" (991mm) deep enclosure**  
Cost effective solution for shallow servers and tower (non-rackmount) technology. Depth includes front and rear door.



**42" & 48" (1069mm & 1219mm) deep enclosure**  
Accommodates deeper server technologies while providing ample cable and power management provisions in the rear integrated channel. 42" shown on left. Depth includes front and rear door.

# Frequent technology refreshes — one enclosure platform

## Standardization

Many of our customers have chosen to standardize on the Vantage S2 because of Eaton's superior rack technology, first-class customer service and convenient local representation to respond to your changing requirements.

Standardization not only eases procurement and vendor management, but it helps drive out waste due to fluctuating costs, inconsistent quality and varying customer support and responses from vendors.

Vantage S2 lends itself to standardization with an open platform that can accommodate everything from Oracle's Sun server dimensions and mounting methods to HP's high-density blade technology that requires a high weight load capacity.

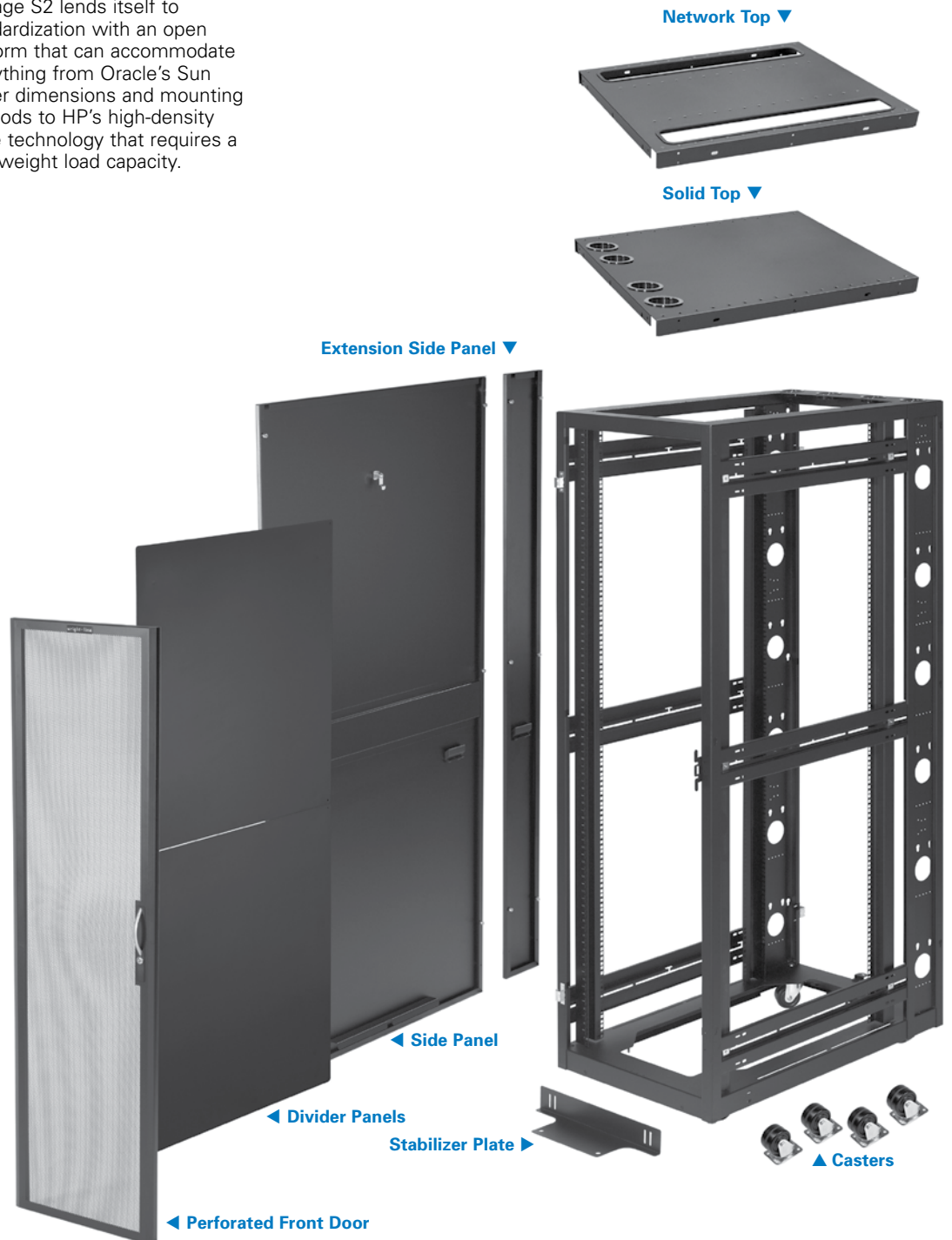

**Heat Containment System (HCS) ▶**

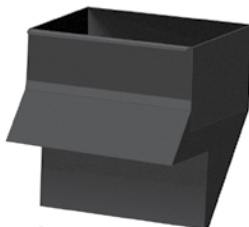

◀ Lacing Bar

◀ 6" (152mm) Extension Frame



◀ Split Perforated Door



◀ Perforated Door



**Roll-out Shelves**  
Our 1U (100 pound/45kg) or 2U (200 pound/91kg) roll-out shelves support non-rackmount equipment that requires easy, all-around access.



**Fixed Shelves**  
Our less than 1U (200 pound/91kg) and 1U (400 pound/182kg) fixed shelves support even the heaviest non-rackmount equipment.



**Utility Drawer/Worksurface**  
Our 3U or 4U storage drawer keeps peripheral equipment like CDs, DVDs, mice and manuals handy and doubles as a worksurface that can support a laptop.

**Vantage S2 Features:**

- Top panel provisions for Overhead Cable Management System offer flexibility and ease of deployment
- Reversible and tool-less doors to ease in-field changes
- Reversible top panel for flexible cable management access
- Half-height divider panels for ease of deployment
- Baying hardware included
- 0.375" (9.52mm) square holes, #10-32 and #12-24 threaded hole vertical rail options
- 583 sq. in. (14,808mm<sup>2</sup>) of open space in the base for bottom cable entry
- Split rear doors that require less clearance in the service aisle
- Top access leveling guides to increase speed of deployment

# Innovative Airflow Management Solutions

At Eaton, we understand how air works in the data center. Unlike other approaches that simply insert more fans in the enclosure or utilize spot cooling devices in the row, our Vantage S2 Enclosure System features a modular design that addresses air volume, air direction and heat exhaust within the enclosure. As your applications grow or you consolidate servers, cooling capacity can be increased simply by modifying the doors, side panels and tops of your enclosure system. The base enclosure remains the same, lowering your Total Cost of Ownership (TCO).

## Heat Containment System® (HCS)

Eaton's patented HCS is a simple, scalable and low cost solution to cool up to 25 kW or more per enclosure without the expense of adding supplemental CRAC units to your data center. The HCS contains and directs the heat exhaust of your IT equipment through the chimney that is attached to the top rear of the enclosure. The hot air is then ducted to your existing CRAC units through the plenum ceiling or high air returns.

## HCS Features and Benefits:

- Scalable heat containment
- Increased rack capacity
- Save white space
- Increase CRAC cooling efficiency
- Create a predictable environment



## Vantage S2 Cooling Scalability with solid side and top panels

Load (kW)	Rear Door
Up to 3.5 kW	Perforated Door
Up to 4.5 kW	Solid Door with two fan trays – 440 CFM (748m <sup>3</sup> /h)
Up to 8.5 kW	Solid Door with four fan trays – 880 CFM (1495m <sup>3</sup> /h)
Up to 26 kW	Solid Door with Active HCS – 250 CFM (4240m <sup>3</sup> /h)
Up to 30 kW	Solid Door with Passive HCS

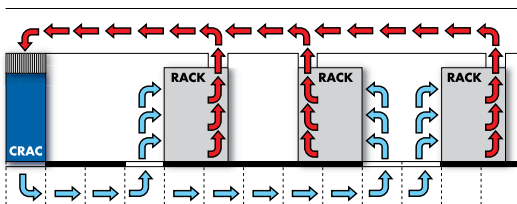

## HCS Cooling Methodology

Vantage S2 has been designed to fit seamlessly into a flooded supply with fully ducted return layout—shown above.\*

## HCS

Easily adapt the HCS to your existing Vantage S2 or third-party enclosures.



\*As outlined in "Thermal Guidelines for Data Processing Environments" by ASHRAE (American Society of Heating, Refrigeration and Air Conditioning Engineers, Inc.)



## Aisle Containment Solutions

Industry studies indicate that an estimated 60 percent of the cool air supplied to traditional data centers is wasted because it bypasses the intended IT equipment and returns directly to the hot air intake of the CRAC.

Adopting a cold or hot aisle containment strategy increases air efficiencies, allowing a significant reduction of cold air supply, translating to longer hardware life and valuable energy savings.

Eaton's solutions can be equally effective for both hot and cold aisles in the data center.

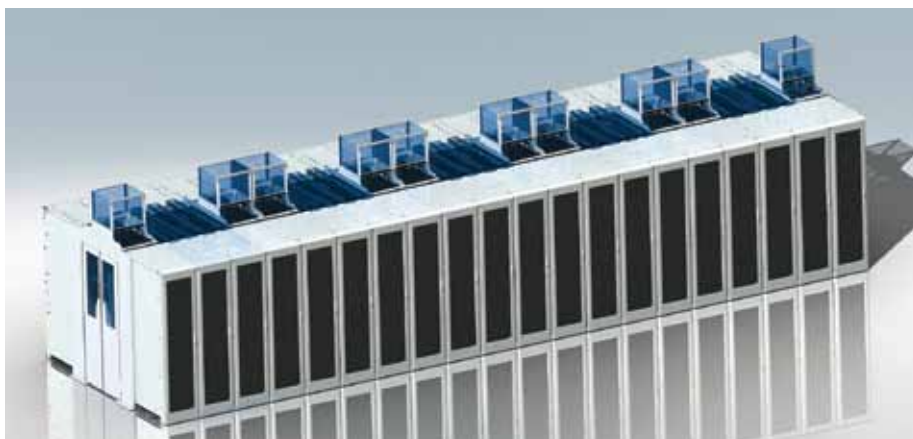

### Total Aisle Containment

Gain total control of your airflow dynamics by utilizing Eaton's aisle containment ceiling, aisle containment duct and end of row doors which complete the total aisle containment solution.

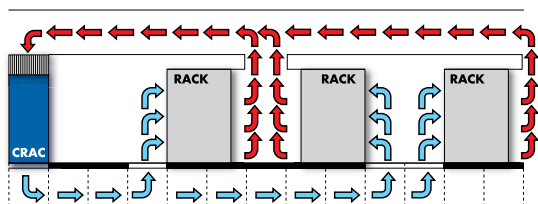

### Aisle Containment Methodology

Control the airflow in your aisle regardless of your containment strategy. Flooded supply with locally ducted return—shown above.\*



### Raised floor grommet

By installing Eaton's raised floor grommets, you can optimize the effectiveness of existing cooling equipment and manage increasing heat loads. The raised floor sealing system specifically addresses bypass airflow and its detrimental effect on data center cooling.



### Tool-less blanking panels

Significantly reduce re-circulation of hot exhaust air to the equipment inlet. Available in 1U, 2U and 8U sizes.



### Flexible return duct system

For data centers unable to accommodate steel chimneys, an alternative solution is the flexible return duct. A simple interface easily connects to the top of the HCS chimney. Flexible 10" ducts are clamped to the interface and a 24" x 24" ceiling tile, which is mounted to the plenum ceiling to create a closed loop system.

# Integrated Power Management Solutions



Vantage S2 is designed to support the most demanding mission-critical power applications, while remaining scalable to accommodate future requirements.

Vantage S2 provides superior power management through a full solution of power distribution and backup power. Eaton's power distribution solutions provide basic, monitored, switched and managed capabilities and backup power solutions range from .5 kVA up to 15+ kVA.

## Three-phase power distribution

Running three-phase power directly to the rack reduces the required number of feeds/whips/drops, resulting in lower installation costs. In addition, three-phase power offers the flexibility of providing 120V and 208V receptacles on a single unit. Eaton offers a broad range of three-phase power distribution solutions and also offers a 400V solution.



## Three-phase rack power distribution

Easily handle today's increasing power requirements with three-phase ePDUs from Eaton.



## Rackmounted power distribution

Eaton ePDUs offer safe, efficient and reliable power distribution.

## Basic/monitored/switched power

Eaton's ePDU™ broad product line offers a reliable solution to your every day power distribution needs. From basic solutions, to monitoring at the outlet level, Eaton provides horizontal and vertical rackmounted solutions from 1-15+ kVA. The plug-and-play architecture, industry leading software and space-saving mounting options make these units the perfect solution for your IT environment.

## Space-saving mounting options

Installing your new ePDU is quick and easy. There are models that mount horizontally in minimal rack space (1U or 2U), or vertically in rack side pockets or rear channels or on a wall or floor, saving traditional U space for IT equipment.

The units come with all mounting hardware included, ready to install. There's no need to purchase additional mounting hardware or accessories. Some units use a button-mount system and can be mounted in keyhole-type openings in popular racks, with no tools required.



ePDU mounted horizontally in rack



ePDU mounted vertically in rack

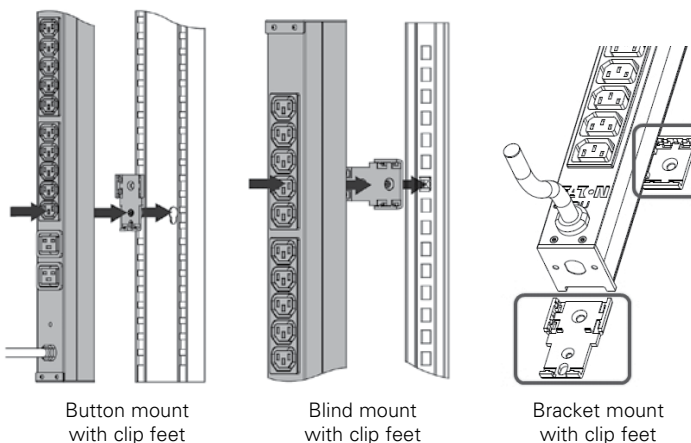

Button mount with clip feet

Blind mount with clip feet

Bracket mount with clip feet

## Benefits of vertical mounts

Eaton ePDUs can be mounted vertically, allowing you to save valuable space. You can mount them vertically in rack side pockets, rear channels, or on a wall, which allows you to save traditional U space for IT equipment.

## Uninterruptible power supply

Eaton helps protect critical equipment by providing uninterruptible power, backup power systems and power management through rack-based UPSs. Eaton delivers clean and efficient backup power from the desktop to the data center, protecting your critical IT systems. These units are integrated with ABM® technology, which increases battery service life up to an additional 50 percent.



### BladeUPS

The scalable and modular BladeUPS expands power protection from 12 to 60 kW in a single 19" rack. Key solution for blade server and data center environments.



### 9130 Rack UPS

The 9130 UPS delivers premium performance with a 0.9 power factor and with greater than 95 percent efficiency. Key solution for small to medium business data centers and networking solutions.



### 5PX Rack/Tower UPS

The 5PX UPS offers integrated power management with 99 percent efficiency and up to 28 percent more power available. Key solution for networking and server applications, as well as virtual environments.

# Cable Management — made simple

Vantage S2's unique platform addresses cable and access management concurrently. From a structural standpoint, Vantage S2's frame design efficiently accommodates large quantities of cables and provides unmatched enclosure-to-enclosure, raised floor and overhead cable access. This approach is not only crucial to safeguarding cabling, but it is required to maximize airflow and provide clear, easy access to equipment.

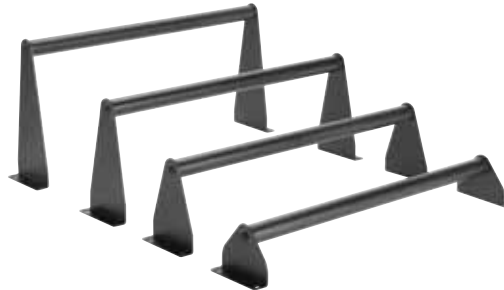

#### **Cable Strain Relief**

Avoid unnecessary cable bends and breaks with strain relief bars that gradually transition cables from a horizontal to a vertical position.

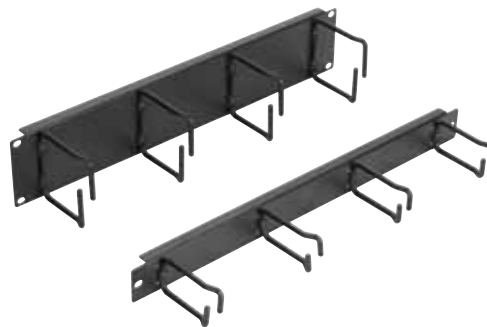

#### **1U/2U Cable Ring Organizer**

Effective horizontal cable management. Also available as a kit of four individual rings.



#### **Lacing Bar**

Flexible management bar for attaching / mounting cables and power strips.



**Overhead Cable Management**  
Allows users to route cables on top of the enclosure and offers separate rows for power and data cables.

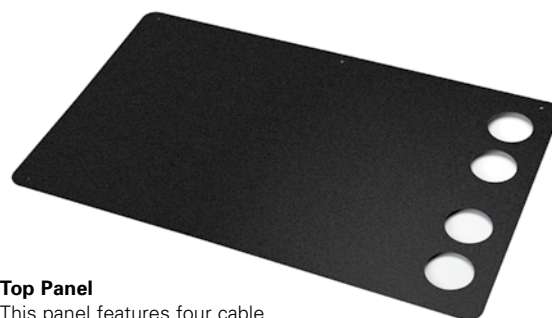

**Top Panel**  
This panel features four cable management holes that can be positioned on either end of the enclosure based on cable entry points.

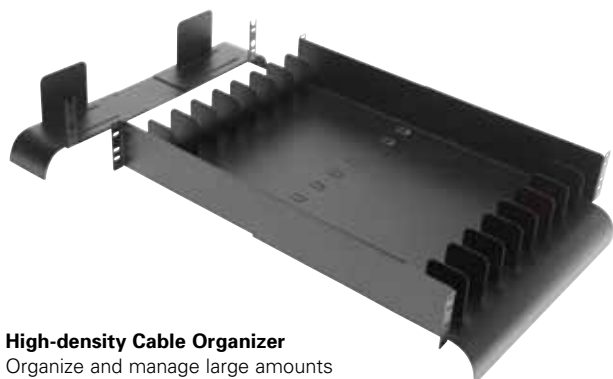

**High-density Cable Organizer**  
Organize and manage large amounts of cables front-to-rear in compliance with TIA/EIA-568-A bend radiuses.

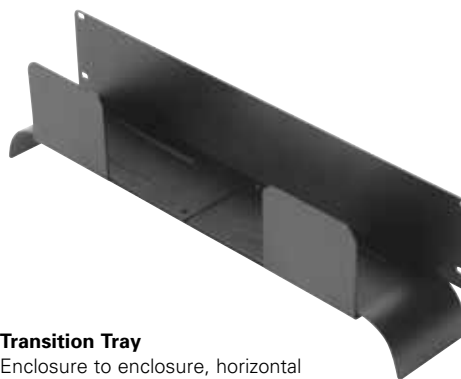

**Transition Tray**  
Enclosure to enclosure, horizontal cable management with TIA/EIA-568-A compliant bend radiuses.



**Take-up Spools**  
Efficient and TIA/EIA-568-A compliant organization of excess cabling within the enclosure.



**Rear Channel**  
The integrated rear channel provides an efficient space to properly manage cables using cable rings or Velcro® straps.



**Velcro Buckle Straps**  
Offering superior strength, our reusable Velcro buckle straps are available in 9" (229mm) and 12" (305mm) lengths to manage cable loads.



# Network Management

A broad range of products provide streamlined solutions for management of the network. By combining keyboard, video and mouse (KVM) switching, LCD displays and environmental monitoring products, we offer flexible connectivity, efficient switching and convergence of technologies.



## IP or Analog CAT5 KVM

Eaton offers a large selection of the industry's best performing KVM switches, including single, dual and multi-user models. Port densities range from 8 to 32 (for both IP and analog models).



## Data Center Management

Eaton offers a Remote Access Management Platform that allows customers to quickly and efficiently access, troubleshoot and fix servers and devices in the data center, server room or locations around the world from a single web-based interface.



## IP Gateways

IP Gateways enable customers to upgrade virtually any analog KVM switch, regardless of manufacturer, to an IP KVM switch. Additionally, the family has a single port IP KVM (PX) with virtual media, perfect for remote offices and MSPs.



## Rackmount LCD Monitors & KVM

Our LCDs are available with an integrated 16 port IP or analog KVM switch and in a two-user model that supports up to 32 ports. All models come in a seamless 1U from factor.



## Extenders

Eaton offers an extensive line of KVM, Serial, USB, Audio, Audio/Video and Video CAT5 extension products.



# Protecting your Investment

Security remains a growing concern in today's data center environments. After all, the life-blood of your business is running on the equipment that is stored and monitored within your enclosures. In addition to the storage, thermal and cooling issues Vantage S2 solves, it also offers a wide selection of safeguard and security devices that protect the mission-critical equipment behind your enclosure doors.

With security appliances and accessories ranging from standard key locks to electronic access control and graphical management tools, you can rest assured that we're completely focused on the deployment and reliability of your systems.



## Cages

Provide the ultimate level of security for your valuable information systems. The cage system is the perfect solution for data center environments requiring subdivision or a higher level of security.



### Standard Locks

High quality standard locks feature 125 key options with master override.



### Swing Handle

Cost effective locking handle that will hold in position with and without the use of keys.



### Combination Lock

Mechanical handle with combination lock and override key. Cost effective multi-layer security.



### Friction Lock

Kaba Mas self-powered friction lock offers advanced yet traditional access keypad.

To contact an Eaton salesperson or  
local distributor, please visit  
[www.eaton.com/wrightline](http://www.eaton.com/wrightline) or call  
**800-225-7348**

**Eaton Corporation**  
Electrical Sector  
1111 Superior Avenue  
Cleveland, OH 44114  
United States  
877-ETN-CARE (877-386-2273)  
Eaton.com

© 2011 Eaton Corporation  
All Rights Reserved  
Publication No. RACK03FXA/WP-5K/8-11



ABM, BladeUPS, Eaton and ePDU are trade names, trademarks and/or service marks of Eaton Corporation or its subsidiaries and affiliates. All other trademarks are property of their respective owners.