

**SC SERIES**

**ACCESS  
FLOOR  
SYSTEM**

**CAMINO**

**MODULAR SYSTEMS INC.**

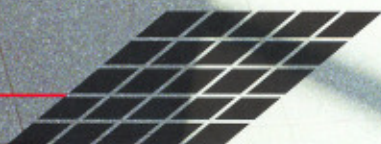

# Office Environment

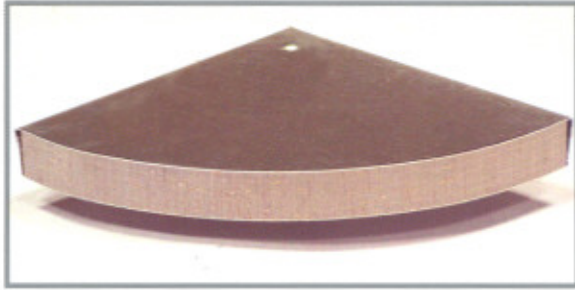

<b>Series 1000 Standard Duty</b>	<b>1000 lbs./sq.in.</b>	<b>4.4 kN</b>
<b>Series 1250 Medium Duty</b>	<b>1250 lbs./sq.in.</b>	<b>5.6 kN</b>
<b>Series 1500 Heavy Duty</b>	<b>1500 lbs./sq.in.</b>	<b>6.6 kN</b>

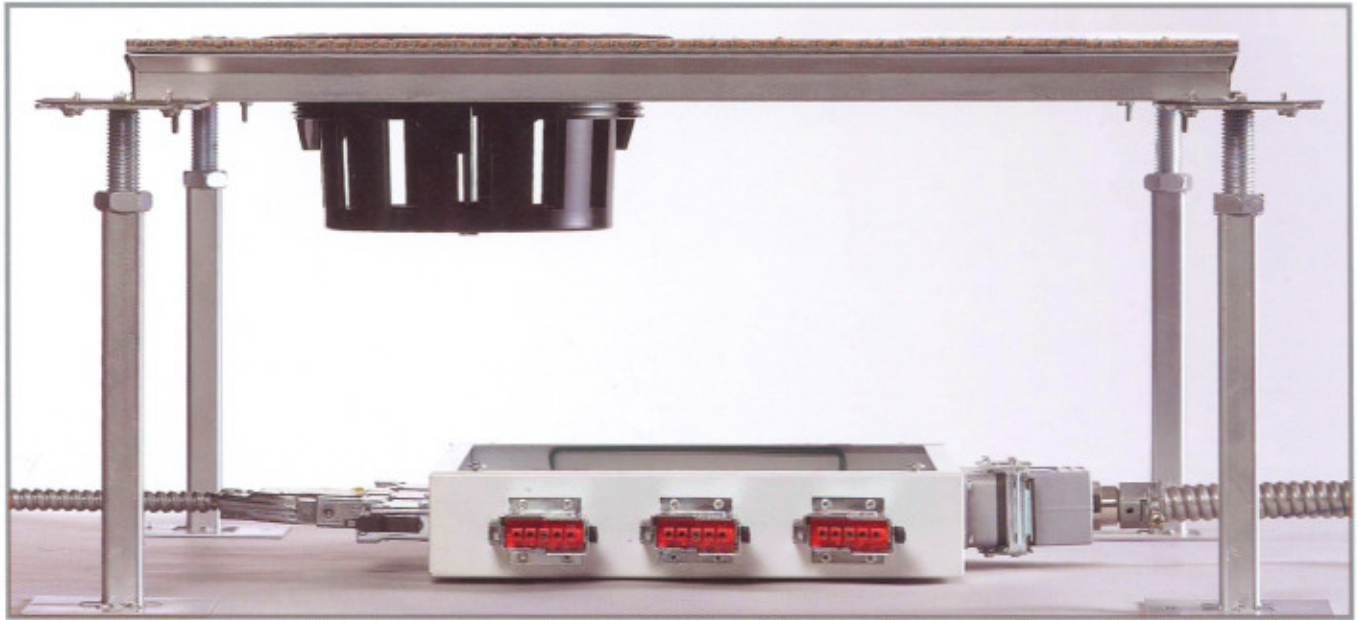

**CORNER BOLT**



**HOOK AND LOCK**

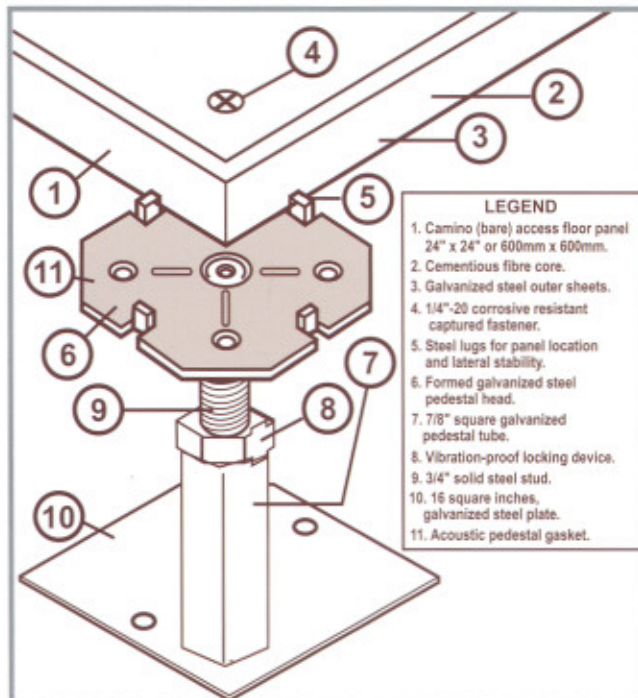

**CORNER LOCK DETAIL**

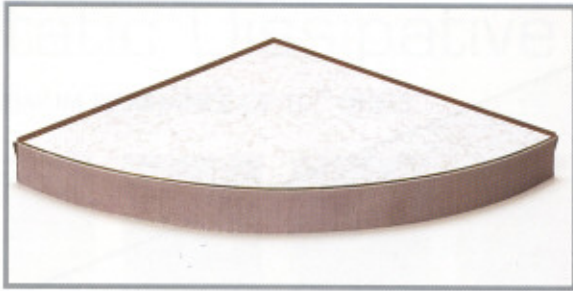

<b>Series 1000 Standard Duty</b>	<b>1000 lbs./sq.in.</b>	<b>4.4 kN</b>
<b>Series 1250 Medium Duty</b>	<b>1250 lbs./sq.in.</b>	<b>5.6 kN</b>
<b>Series 1500 Heavy Duty</b>	<b>1500 lbs./sq.in.</b>	<b>6.6 kN</b>
<b>Series 2000 Industrial Duty</b>	<b>2000 lbs./sq. in.</b>	<b>8.8 kN</b>

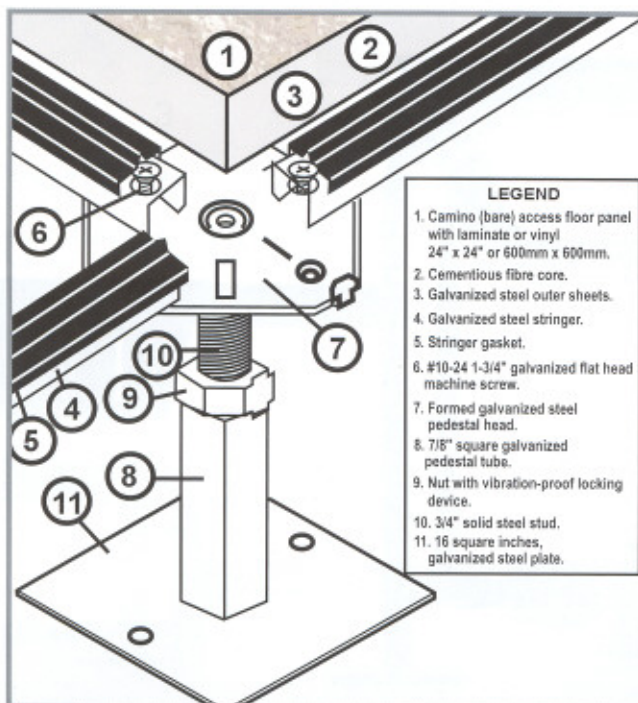

**STRINGER DETAIL**



**STRINGER SYSTEM**

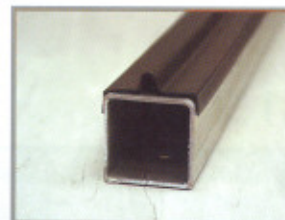

**HEAVY DUTY  
WELDED TUBE  
STRINGER**

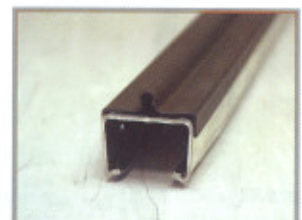

**STANDARD  
ROLL FORMED  
STRINGER**

# Unlimited Choice of Floor Heights and

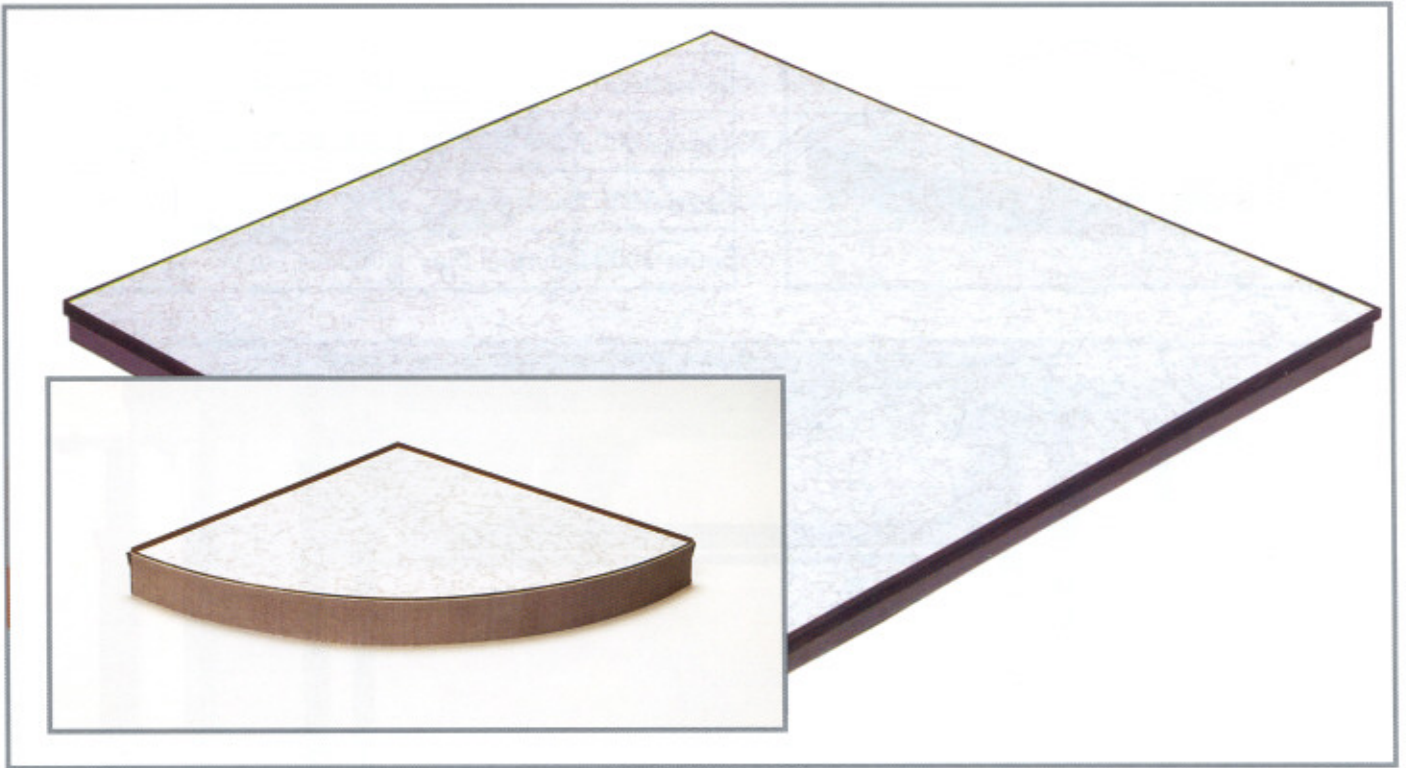

**12" - 24"**  
Finished Floor Height

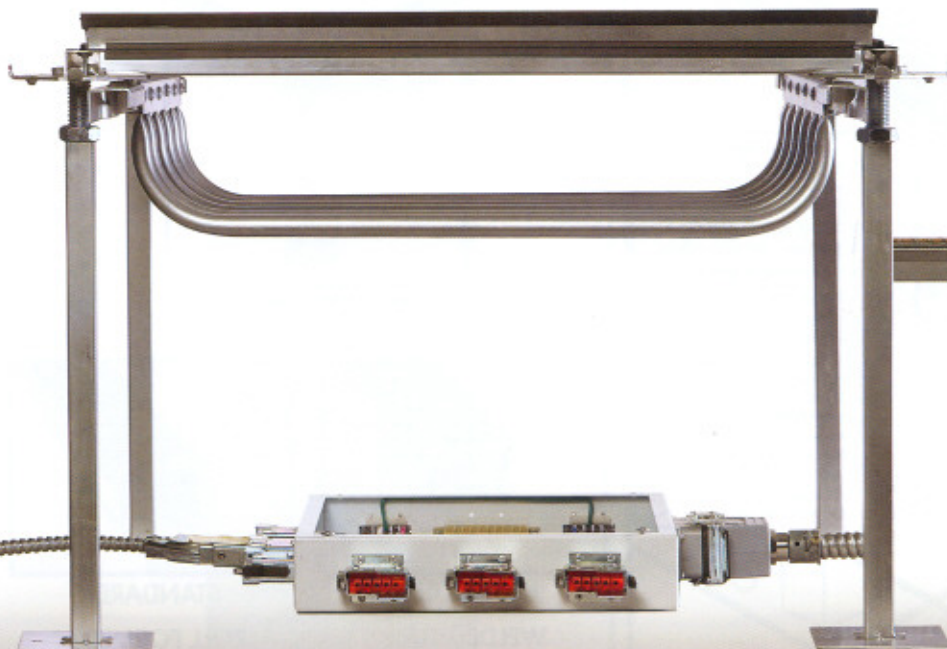

**8" - 18"**  
Finished Floor Height

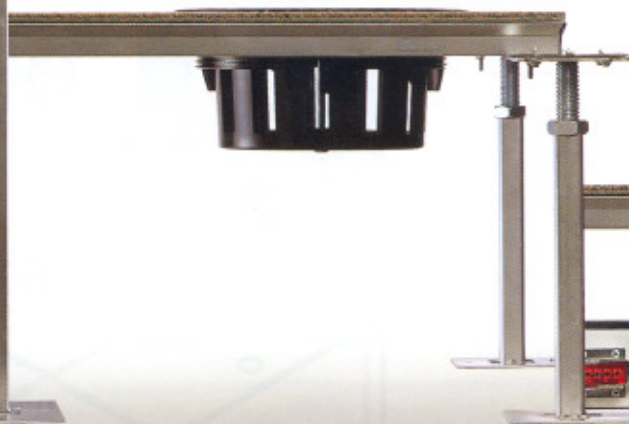

# Static Dissipative Finishes

## Static Dissipative Laminate

MAXIMUM RESISTANCE OF  $10^{10}$  OHMS

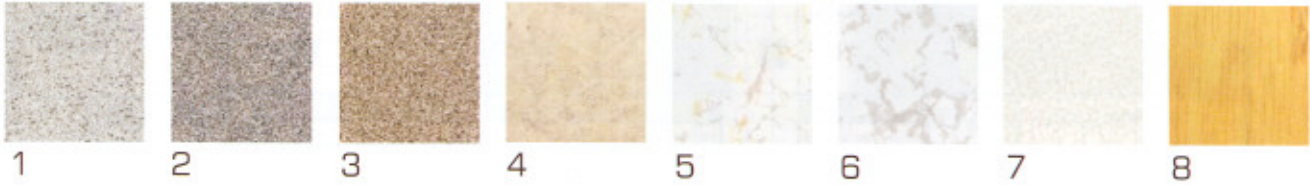

## Conductive Laminate

MAXIMUM RESISTANCE OF  $10^6$  OHMS



## Conductive Vinyl

MAXIMUM RESISTANCE OF  $10^6$  OHMS

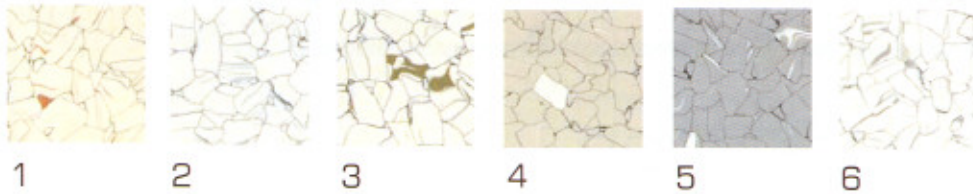

## Conductive Vinyl

MAXIMUM RESISTANCE OF  $10^6$  OHMS

4" - 6"

Finished Floor Height



# CAD and Engineering Support for Data Centers

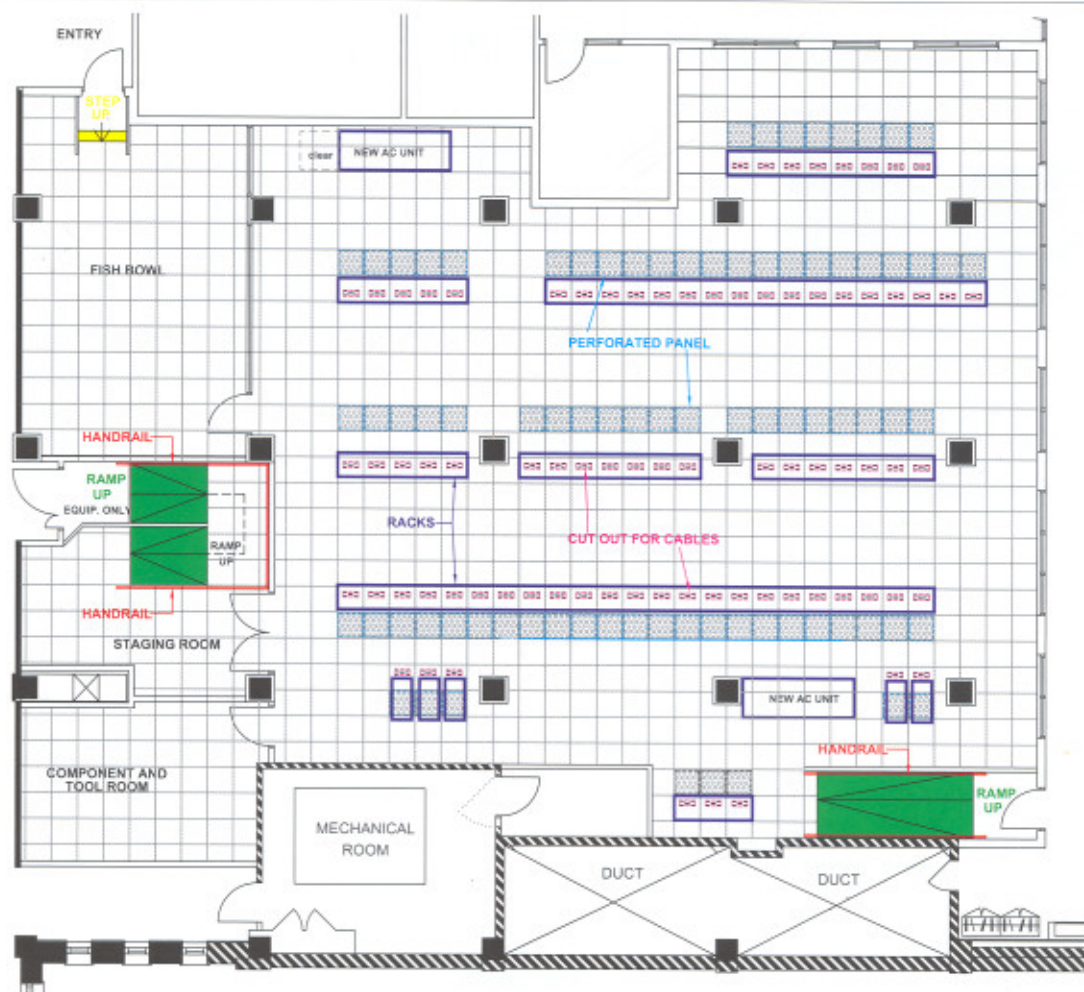

## Short Form Specification

### Data Center

**Panel:** 24"x 24" steel panel with non-dusting cementitious composite core.  
**Finish:** Static dissipative high pressure laminate by Nevamar or Formica. Manufacturer's standard color range.  
**Understructure:** Bolted stringers on adjustable steel pedestals.  
**Concentrated Load:** 1500 lbs./sq.in. at weakest point. Maximum deflection of 0.100in.  
**Rolling Load:** 1200 lbs./10 passes; 800 lbs./10,000 passes. Maximum permanent surface deformation of 0.040 in.  
**Ultimate Load:** Minimum 3000 lbs./sq. in. or safety factor of 2.  
**Flammability:** flame spread: 0, fuel contribution: 0, smoke development: <5  
**Test Procedures:** CISCA  
**Panel Weight:** Maximum 29 lbs. each  
**Ramp/Step/Handrail Kits:** Manufacturer's standard.  
**Cut Outs:** Field cut with vinyl trim.  
**Air Flow Panels:** Manufacturer's standard perforated steel panel.  
**Manufacturer:** Camino SC1500 Series. Tel 1-800-370-0226

### Office

**Panel:** 24"x 24" steel panel with non-dusting cementitious composite core.  
**Finish:** Bare  
**Understructure:** Stringerless cornerlock on adjustable steel pedestals.  
**Concentrated Load:** 1300 lbs./sq.in. at weakest point. Maximum deflection of 0.100in.  
**Rolling Load:** 1200 lbs./10 passes; 800 lbs./10,000 passes. Maximum permanent surface deformation of 0.040 in.  
**Ultimate Load:** Minimum 2600 lbs./sq. in. or safety factor of 2.  
**Flammability:** flame spread: 0, fuel contribution: 0, smoke development: <5  
**Test Procedures:** CISCA  
**Panel Weight:** Maximum 27 lbs. each  
**Box Cut Outs or Grommets:** Manufacturer's standard.  
**Ramp/Step/Handrail Kits:** Manufacturer's standard.  
**Manufacturer:** Camino SC1300 Series. Tel 1-800-370-0226

# Accessories



LIFTERS



RAMP/HANDRAIL KITS



STEP/HANDRAIL KITS

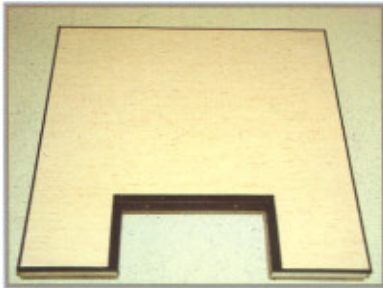

STANDARD VINYL  
TRIM CUTOUT



CUT OUT TRIM  
WITH BRUSH INSERT



REINFORCEMENT PEDESTALS  
FOR HEAVY LOADS SUCH AS  
UPS AND BATTERY RACKS

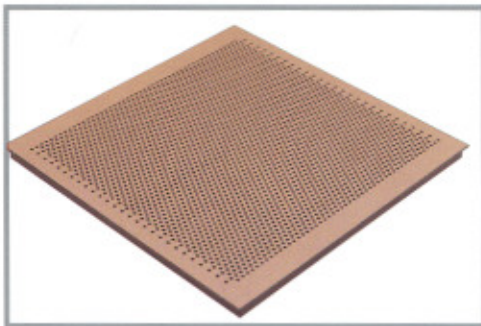

PERFORATED AIR FLOW PANEL

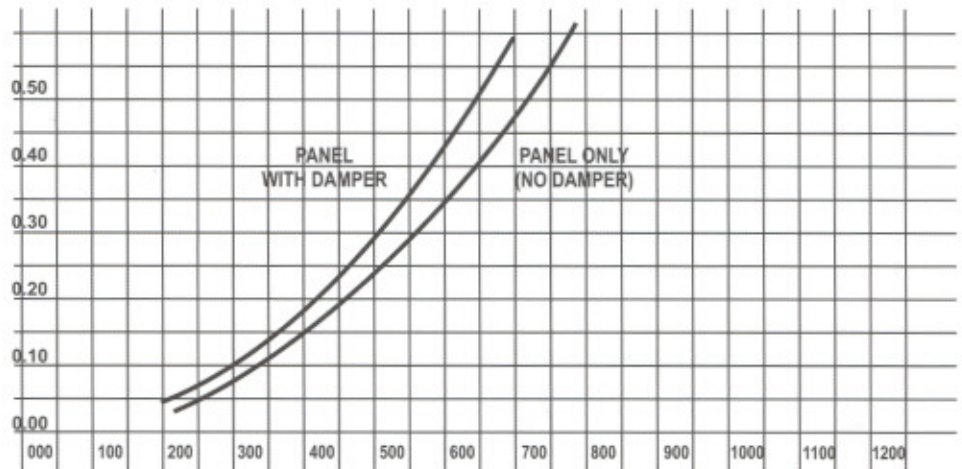

AIR FLOW PANEL  
VOLUME - SOLID LINE-CUBIC FEET/MINUTE



CABLE TRAY

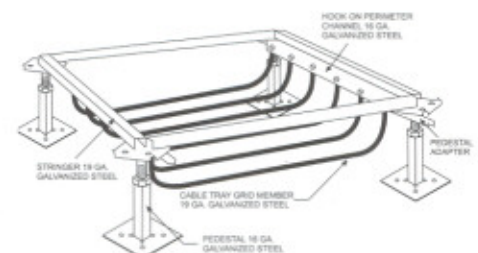
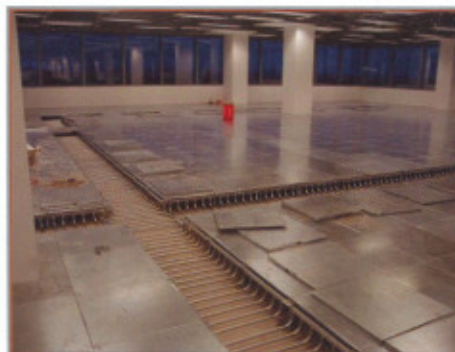

**Camino Modular Systems Inc. established in 1970 is an international supplier of access floor systems.**

**Head Office and Factory**

89 Carlingview Drive  
Toronto, Ontario, Canada  
M9W 5E4  
Tel: 416-675-2400 / 1-800-370-0226  
Fax: 416-675-2424 / 1-866-370-0226

**Mid West Regional Sales Office**

Chicago, IL  
Tel: 847-427-1800  
Fax: 847-427-8173

**Southern Regional Sales Office**

Dallas, TX  
Tel: 972-788-2770  
Fax: 972-866-9160

**West Coast Regional Sales Office**

Vancouver, BC  
Tel: 604-267-2400  
Fax: 1-866-370-0226

[www.camino-access-floors.com](http://www.camino-access-floors.com)

**Camino access floors have been installed for many of the worlds leading companies, including:**

A.C. Nielson  
Air Canada  
Allstate Insurance  
Amdahl  
AT&T  
Bank of Moscow  
Bank of Montreal  
Bank of Nova Scotia  
Banko Sandander  
Bell Telephone  
Cantel  
Charles Schwabb  
Chase Manhattan Bank  
Chrysler  
CIBC  
Citicorp Bank  
Clearnet  
Coca Cola Ltd.  
Credit Suisse  
Dai Ichi Bank  
Deacon Barclays Bank  
Dean Witter

Department of Defense  
Discovery Museum  
Dow Chemical  
Exxon  
Ford Motor Company  
FUJI  
General Motors  
Hewlett Packard  
Hydro Quebec  
IBM  
Kenya International Airport  
Labatt's Brewery  
Loblaws Head Office  
MacMillan Bloedel  
Mayo Clinic  
McDonnell Douglas  
MCI  
Microsoft  
Ministry of Finance  
Ministry of Transportation  
Molson's Brewery  
Morgan Guaranty Trust

Motorola  
Ontario Hydro  
Oracle Corporation  
Pacific Bell  
Pitney Bowes  
Public Works Canada  
RCMP  
Rockwell International  
Rogers Communications  
RBC Royal Bank  
Shell Oil  
Société Immobilière du Québec  
Société Générale  
Sprint  
Teleglobe  
TD Bank  
United Airlines  
U.S. Air Force  
U.S. Navy  
Volkswagen  
Union Bank of Switzerland

**CAMINO**

MODULAR SYSTEMS INC.

