

Eaton's SPD Series



Introduction

Eaton's SPD Series surge protective devices

Eaton's SPD Series surge protective devices are the latest and most advanced UL® 1449 3rd Edition certified surge protectors. Application of SPD Series units throughout a facility will ensure that equipment is protected with the safest and most reliable surge protective devices available. Units are available in all common voltages and configurations, and also in a variety of surge current capacity ratings from 50 through 400 kA. Three feature package options are also available to choose from.

Applications

The increasing necessity for facility-wide surge protection

The ever-increasing use of microprocessors and other sensitive electronic equipment has increased the necessity for facility-wide surge protection. These sensitive electronic components are used within many pieces of equipment, including computers, programmable logic controllers and other commonly used electrical and electronic equipment. Surges can wreak havoc on equipment, causing catastrophic failures, process interruptions and premature aging leading to failure. The application of surge protective devices (SPDs) can mitigate problems with sensitive electronic equipment, keeping the equipment and the related processes up and running reliably without disruption or damage due to surge-related events.

In addition to externally generated surge events, such as lightning and grid switching, equipment is also susceptible to damage by internally generated surges. In fact, the majority of surges are generated internally by commonly used items, such as fluorescent lighting ballasts, light dimmers, photocopiers, fax machines and variable frequency drives. This further reinforces the necessity for facility-wide surge protection applied at all stages of the electrical distribution system, from the electrical service entrance down to the single-phase loads.

Pending standards and certifications

- UL 1449 3rd Edition
- Canadian Standards Association (CSA®)



Features

- Utilizes thermally protected metal oxide varistor (MOV) technology
- 20 kA nominal discharge current (I_n) rating (maximum rating assigned by UL)
- 50 through 400 kA surge current capacity ratings
- Three feature package options
- Factory-sealed assembly prevents arc flash and shock hazards
- Contains no replaceable parts or items that require periodic maintenance
- Optional internal disconnect available
- 200 kA short circuit current rating (SCCR)
- 10-year warranty

The breadth of the SPD Series' features, options and configurations ensures that the correct unit is available for all electrical applications.



Powering Business Worldwide

The SPD Series makes surge suppression safer than ever

The SPD Series employs safety and design features that make surge protection safer than ever. Unlike many surge protective devices, the unit contains no user-serviceable parts or items that require periodic maintenance, such as replaceable surge modules, replaceable fuses, surge counter memory backup batteries or wire lugs that require periodic retightening. All SPD Series units are factory-sealed, meaning no potential contact with harmful voltages present within the unit is possible.

The SPD Series has also taken safety to the next level by using thermally protected MOVs as its core surge suppression component. These thermally protected MOVs operate in a safe manner, even when subjected to abnormal conditions, such as temporary overvoltages or high fault current conditions. When one of these conditions exists, the thermally protected MOVs are removed from the circuit quickly and safely before a potentially unsafe condition can occur, with absolutely no discharge of smoke or ionized gases. Using the latest in technology and surge protective device design, the SPD Series provides safe, reliable, worry-free surge protection.

Prewired

All units are prewired at the factory and contain a factory-installed conduit interface, making installation very easy. Simply mount the unit, perform any required conduit runs and land all required wires to the electrical assembly the unit is being interfaced with. No internal wiring connections or access to the inside of the unit is required.

Factory-sealed

All units are factory-sealed. This preventive safety measure eliminates potential arc flash and shock hazards, as the user/installer has no chance of coming into contact with energized electrical components within the unit. In addition, the unit contains no user-replaceable or serviceable items, such as surge modules, fuses, backup batteries for the surge counter's memory or wire lugs that require periodic retightening. Factory-sealing all units, coupled with the lack of replaceable items, further increases user safety, as no contact with live electrical parts is neither possible nor necessary.

Compact size

SPD Series units are compact in size, taking up less space in the electrical room. Units housed in NEMA® 1 rated enclosures in the 50 kA through 200 kA surge current capacity range are housed in a 74-square-inch enclosure that is only 3.5 inches deep. Units housed in NEMA 1 rated enclosures in the 250 kA through 400 kA surge current capacity range are also housed in a 74-square-inch enclosure that is only 6.0 inches deep.

Enhanced protection status indicators

The SPD Series has elevated the features normally found within surge protective devices to the next level. Unlike many surge protectors that may have only single-colored indicators that simply indicate whether power is applied to the surge protective device, each unit includes dual-colored protection status light emitting diodes (LEDs) that indicate the true status of the protection. On three-phase units, if power is removed from a phase, the unit's protection status LEDs continue to indicate the status of the protection on that phase, not the status of the power applied to the phase. This new feature ensures that the user is supplied with accurate information concerning the status of the protection the SPD is supplying on the phase, not the status of the power applied to the phase.

All units that require a neutral wire connection also contain an additional set of dual-colored LEDs that report the status of the protection in the neutral-ground (N-G) protection mode. Like the phase protection status LEDs, the N-G protection status LEDs also report the true status of the protection in the N-G mode.

Although most SPDs on the market contain N-G mode protection, they do not monitor and indicate the status of the protection in that mode. Specifying the N-G protection mode status indication feature will ensure that users are supplied with complete and accurate information concerning the surge protective device's protection status.

20 kA nominal discharge current rating (I_n)

The entire SPD Series product offering has a nominal discharge current (I_n) of 20 kA, the highest achievable rating for this important parameter. This is a new

rating for SPDs that is included as part of UL 1449 3rd Edition testing and certification. This rating provides an indication of the SPD's design robustness and ability to handle a number of large-magnitude surges over a short period of time and remain operational within tested parameters.

During I_n testing, the SPD is subjected to 15 surges of a current magnitude chosen by the SPD's manufacturer. Valid current magnitude choices for the test are 20 kA and 10 kA for Type 1 SPDs. Valid choices for Type 2 SPDs are 20 kA, 10 kA, 5 kA and 3 kA. The 15 surges are then applied at the value chosen by the manufacturer.

Prior to the start of I_n testing, a preliminary voltage protection rating (VPR) is measured. The VPR is the measured let-through voltage of the unit when a 6 kV, 3 kA surge is applied. This value is documented and saved as a reference. After all surges have been applied, the VPR is measured once again and compared to the value that was recorded prior to the 15-surge sequence. In order to pass the I_n test, the SPD must survive all 15 surges, and the measured pre- and post-VPR values must be within ±10% of each other.

Choosing an SPD with an I_n of 20 kA ensures that your equipment is being protected by a unit that will continue to maintain a high level of surge protection performance, even after being subjected to multiple high-magnitude surges.

Industry standards for lightning protection systems require the installed SPDs to have a nominal discharge current of 20 kA. The 2008 Edition of National Fire Protection Agency (NFPA) Standard 780, titled "Standard for the Installation of Lightning Protection Systems," states the requirement in Section 4.18.3.1.2. The 2007 Edition of Underwriters Laboratories (UL) Standard 96A, titled "Installation Requirements for Lightning Protection Systems," states the requirement in Section 13.1. Choosing an SPD with an I_n of 20 kA will ensure that compliance with these standards can be achieved.

SPD Series Unit



The unit is designed for mounting external to electrical equipment and interfaced via conduit and wires.



All SPD Series units come prewired and contain a factory-installed conduit interface, making installation very easy.



All SPD Series units are factory-sealed, ensuring the user/installer has no potential of coming in contact with hazardous voltages present inside the unit.

Feature package options

The SPD Series provides users with the option of selecting between three feature packages. These feature packages are the basic, standard and standard with surge counter. The proper feature package can be selected based on the requirements of the application or specification.

Basic feature package

The basic feature package is perfect for applications where basic, cost-effective, safe and reliable surge protection is required but budgets don't allow for extra, additional features. Rather than sacrifice performance or safety due to cost, SPD Series units with the basic feature package provide you with high-performing surge protection without sacrificing safety or reliability. The basic feature package provides the same level of surge protection and safety provided by the standard and standard with surge counter feature packages minus some of the features found in them. The package contains dual-colored protection status LEDs that report the true status of the protection in each phase/mode. All four-wire plus ground units also contain an additional set of dual-colored protection status LEDs that report the status of the protection in the N-G mode.

Standard feature package

The standard feature package includes all of the features found in the basic feature package, plus an audible alarm with silence button, EMI/RFI filtering, and a Form C relay contact that can be used for remote annunciation of the SPD's status. The audible alarm activates and the Form C relay contact changes state when any loss of protection is detected or a fault condition exists with the unit. Should such a condition occur, the audible alarm can be silenced by pressing the silence button. The EMI/RFI filter provides up to 50 dB of noise attenuation over the range of 10 kHz through 100 MHz.

Standard with surge counter feature package

The standard with surge counter feature package includes all of the features found in the standard feature package plus a six-digit surge counter with a reset button. The surge counter indicates the ongoing count of the number of surges the unit has been exposed to and stores them in nonvolatile memory. Should power to the unit be completely interrupted, the surge counter will recall and display the surge count prior to the interruption when power is restored. Unlike many surge protectors, the SPD Series' surge counter memory feature does not require a backup battery that would require periodic replacement in order to achieve its memory functionality.

Side-by-side comparison of the SPD Series' available feature packages

Feature Package Comparison	Basic	Standard	Standard with Surge Counter
Surge protection using thermally protected MOV technology	✓	✓	✓
Dual-colored protection status indicators for each phase	✓	✓	✓
Dual-colored protection status indicators for the N-G protection mode	✓	✓	✓
Audible alarm with silence button		✓	✓
Form C relay contact		✓	✓
EMI/RFI filtering, providing up to 50 dB of noise attenuation from 10 kHz to 100 MHz		✓	✓
Surge counter with reset button			✓



Specifications

Description	Ratings
Surge current capacity per phase	50, 80, 100, 120, 160, 200, 250, 300 and 400 kA ratings available
Nominal discharge current (I _n)	20 kA
Short circuit current rating (SCCR)	200 kA
SPD type	Basic Feature Package = Type 1 (can also be used in Type 2 applications) Standard and Standard with Surge Counter Feature Packages = Type 2
System voltages available (Vac)	
Single split-phase (three-wire plus ground)	120/240
Three-phase wye (four-wire plus ground)	120/208, 230/400, 277/480
Three-phase delta (three-wire plus ground)	240, 480
Input power frequency	50/60 Hz
Protection modes	
Single split-phase	L-N, L-G, L-L, N-G
Three-phase wye	L-N, L-G, L-L, N-G
Three-phase delta	L-G, L-L
Operating temperature	-20°C through 50°C (-4°F through 122°F)
Operating humidity	5% through 95%, noncondensing
Pending agency certifications and approvals	UL 1449 3rd Edition listed device; CSA listed; UL 1283 (Type 2 SPDs only)
Warranty	10 years

Catalog number configuration

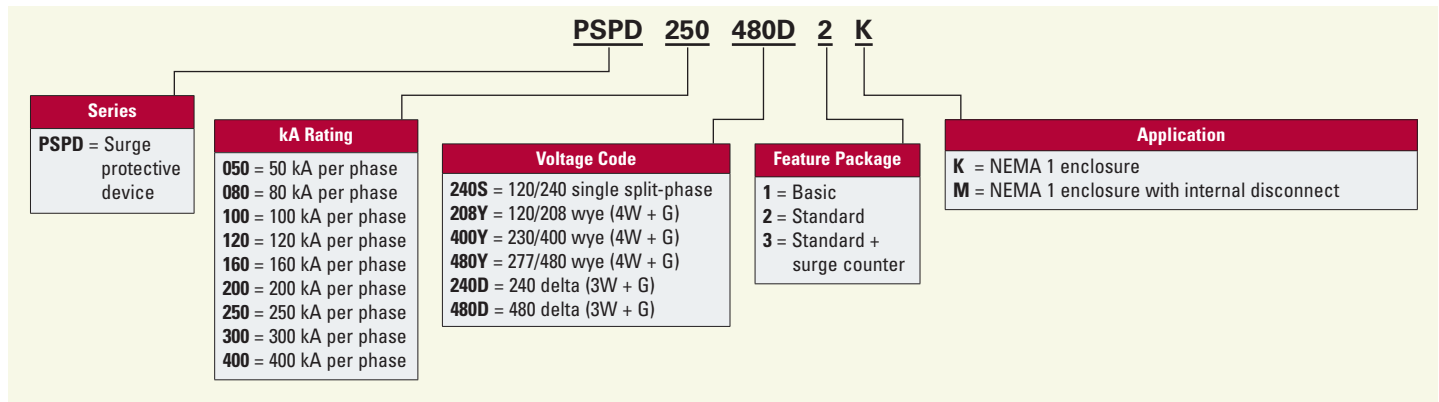

Example: PSPD250480D2K = SPD Series, 250 kA per phase, 480D voltage, standard feature package, housed in NEMA 1 enclosure

Eaton Corporation
Electrical Sector
1111 Superior Ave.
Cleveland, OH 44114
United States
877-ETN-CARE (877-386-2273)
Eaton.com

© 2010 Eaton Corporation
All Rights Reserved
Printed in USA
Publication No. PA01005005E / BC-7
January 2010

EATON
Powering Business Worldwide



PowerChain Management is a registered trademark of Eaton Corporation.

All other trademarks are property of their respective owners.